

General Information

Date / Time : **November 15 (Wed) - 17 (Fri), 2017 10:00-17:00**
 Venue : Tokyo Big Sight East Hall (Tokyo International Exhibition Center, Japan East Hall 6)
 Show Scale : 150 exhibitors / 250 booths(expected / Including Joint Exhibitions)
 Number of Visitors : 9,000 professionals (expected / Including Joint Exhibitions)
 Joint Exhibition : **Japan Home & Building Show 2017** **TOILET TOKYO 2017**
JAPANTEX 2017 **Shop Design 2017**

How to Apply

Please fill out all relevant items on the enclosed Exhibitor Application Form. Those who apply for any exhibition first time organized by the Japan Management Association should also submit a company history or outline, as well as a catalog for all items to be exhibited (or items offered) in advance to the Secretariat.

Application Deadline

July 28(Fri), 2017

*The application acceptance period will be closed when the scheduled number of booths is sold out. *Please be aware that applications from companies whose exhibition items are not deemed appropriate to the Exhibition may be declined.

Exhibitor Cost

One booth = approximately 9.0 sqm (2.97m(W) X 2.97m(D) X 2.7m(H))

Standard Booth

*Consumption tax included

1st Booth **JPY486,000** + After 2nd Booth **JPY432,000**
(per booth)

- Facilities included:**
- Side and back partition walls (white)
 - Electrical wiring work for 100V / 300W (a breaker switch only - no outlet)
 - Booth number plate

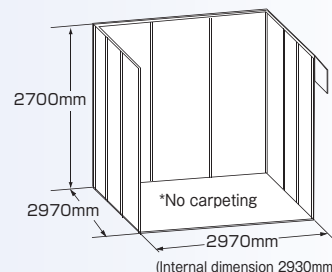

<Attention> * No side wall panels will be installed where there are no adjacent booths.

1 Booth with Package

*Consumption tax included

1st Booth **JPY626,400** + After 2nd Booth **JPY572,400**
(per booth)

- Facilities included:**
- Company name on fascia board
 - Side and back partition walls (white)
 - One information desk
 - Electrical wiring work for 1.0kW (100V / single phase)
 - Usage charge until 1.0kW
 - Booth cleaning for three days
 - Carpeting
 - Booth number plate
 - Three spotlights
 - One power outlet
 - One folding chair

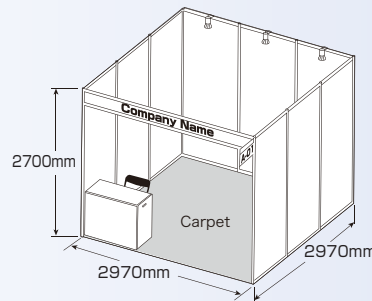

Optional Fees

*Consumption tax included

Corner Booth Choice Fee **JPY86,400**

Booth locations at this show will be assigned by organizer. If an exhibitor does not wish to be assigned by organizer, the exhibitor will have the option of applying for one of the corner locations; the assignment of the latter will be guaranteed.

The Schedule (tentative)

	2017
Early Application Deadline	June 23 (Fri), 2017
Final Application Deadline	July 28 (Fri), 2017
Payment Deadline	August 31 (Thu), 2017
Exhibitors' Explanatory Meeting (Floor Plan Fixture)	Early September
Deadline for Order Form Submissions Booth Decoration Application Deadline	End of September
Move-in Period	November 13(Mon), - 14(Tue), 2017 8:00-18:00 (Overtime is possible with permission.)
BUILDING MAINTENANCE HUMAN FAIR & CLEAN EXPO 2017	November 15 (Wed), - 17(Fri), 2017 10:00-17:00
Move-out Period	November 17(Fri), 2017 17:00-22:00 (Overtime Work NOT permitted.)

Contact **BUILDING MAINTENANCE HUMAN FAIR & CLEAN EXPO Secretariat**
 Japan Management Association(JMA)
 Sumitomo Corporation Takebashi Bldg, 14F 1-2-2 Hitotsubashi,
 Chiyoda-ku, Tokyo, 100-0003, Japan
 Tel: +81-3-3434-1988 Fax: +81-3-3434-8076 <http://www.humanfair-cleanexpo.org/2017/en/>

Exhibition for Sophisticated Building Maintenance and Cleaning Technologies

BUILDING MAINTENANCE HUMAN FAIR

& CLEAN EXPO 2017

Exhibitor Information

Application Deadline

July 26 (Fri), 2017

November

15(Wed) - 17(Fri), 2017 10:00~17:00

Tokyo Big Sight East Hall 6

(Tokyo International Exhibition Center, Japan)

Organizers **JMA** Japan Management Association/

Japan Building Maintenance Association

Joint Exhibition **Japan Home & Building Show 2017**

TOILET TOKYO 2017

The 36th JAPANTEX 2017

Shop Design 2017

<http://www.humanfair-cleanexpo.org/2017/en/>

NEW! Exhibition for Sophisticated Building Maintenance and Cleaning Technologies

BUILDING MAINTENANCE HUMAN FAIR & CLEAN EXPO 2017

ABOUT THE SHOW

✓ "Largest Exhibition in Japan for Facility Maintenance and Cleaning Technologies Organized by 2 Major Industrial Bodies"

This is a Joint Exhibition held by Japan Building Maintenance Association (JBMA) and Japan Management Association (JMA) featuring every possible business in Building Maintenance and Cleaning Technologies. JBMA is well-known as the public welfare body for raising social position and benefit of cleaning, building facility maintenance and security services, furthermore has been holding trade shows for the industry in alternate years since 1991. Meanwhile, Japan Management Association is an incorporated association annually holding over 40 exhibitions for various industries, and has launched "Clean EXPO" in 2014. Both associations will collaborate in merging the shows for organizing "BUILDING MAINTENANCE HUMAN FAIR & CLEAN EXPO", to establish a collective platform for Building/Facility Maintenance Professionals and Owners, and ultimately will become the largest exhibition of its kind in Japan.

✓ Facility Maintenance Professionals, Facility Owners, Makers, Public Sectors, All in One Place

This show guarantees the visit of building maintenance professionals through the network of JBMA's 47 prefectural branches, and the visitor information owned by both JBMA and JMA developed through trade shows. This show's visitor category will aggregately cover the following:

- ◇ Building Maintenance Professionals
- ◇ Building/Facility Owners
- ◇ Agent Prospects for Manufactured Goods
- ◇ Cleaning Services and Franchises
- ◇ Retailers for Cleaning Tools and Equipments

✓ Witness the Leading Cleaning Technologies in Japan

Under the domestic depopulation, makers are developing automated cleaning robots of which are available to be observed with demonstrations in respective booths. Together with product displays, cleaning professionals will be performing cleaning demonstrations on sight, and an award ceremony will be held rewarding the best cleaning staff nominated from 47 prefectural areas of Japan.

EXHIBIT CATEGORIES

● FACILITY MAINTENANCE ZONE

Environmental Sanitation Management

- Infection Control
- Pest Control, Bird Damage Control
- Environmental Measurement
- Water Supply & Drainage Management
- Waste Disposal
- Floor Maintenance
- Periodic Cleaning (Floor Cleaning, Waxing)
- Stone Surface/Wall Maintenance



Building Facility Management

- Facility Control System
- Facility Inspection System
- Interior/Exterior Equipment
- HVAC Cleaning
- Plumbing/Drainpipe Rehabilitation
- Duct, Ventilation System Cleaning
- Custom Commercial Awnings



Building Reform Service

- Renewal Proposals (Plumbing, Elevator, Ventilation)
- Interior Construction, Dismantling
- Seismic, Reinforcement Work
- Barrier-Free Work
- Maintenance-Free Building Materials
- Repair Products



Energy Saving

- LED Lighting, Ventilation Equipment
- Solar Energy Generation System
- Roof Greening
- Energy Saving Equipment Installation
- Energy Management System
- Eco-Tuning



Security Service

- Disaster Prevention
- Crime Prevention System & Equipment
- Cyber Attack Prevention



● CLEAN TECHNOLOGY ZONE

Cleaning Machinery

- Automatic Cleaning Robots
- Vacuum Cleaner
- Washing, Scrubbing Machine
- Polisher
- Air Blower
- Air Cleaner
- Water Purifier



Cleaning Tools, and Gears

- Brush, Mop, Scraper, Gum Wand
- Uniform, Shoes
- Carrier, Wagon
- Equipment Cleaning Tools



Cleaning Agent Chemicals

- Detergent
- Sanitizer
- Remover
- Deodorant
- Wax, Coating
- Antifoulant
- Laundry Soap



Facility and Industrial Hygiene

- Infection Control
- Deodorization
- Interior Disinfection
- Public Washroom Maintenance
- Asbestos Abatement
- Carpet Cleaning
- Exterior Wall Cleaning
- Wall Surface & Ceiling Cleaning
- Cistern Cleaning
- Solar Panel Cleaning
- Glass Cleaning
- Blind Cleaning
- Drainpipe Cleaning
- Kitchen Cleaning



Agency and Software Services

- Cleaning Service Agents
- Client Management System Implementation
- ERP Software Implementation



Visitor Categories on TARGET

- Agents for Distribution
- Maintenance Services
- Facility Managers (Train Stations, Expressway Service Areas)
- Building Owners (Office, Residential)
- Public Facilities (Government, Municipalities, Schools)
- Hospitals (Medical Institutions)
- Welfare & Nursing Facilities
- Hotels / Japanese Inns (Ryokan)
- Stores, Commercial Facilities (Supermarkets, Department Stores)
- Amusement, Recreational Facilities
- Food Service (Restaurants, Cafes)



Floor Plan(Tokyo Big Sight , East Hall)



Tokyo Big Sight Main Entrance



2016 Show Report : Visitor Profile of CLEAN EXPO 2016 and Joint Exhibitions

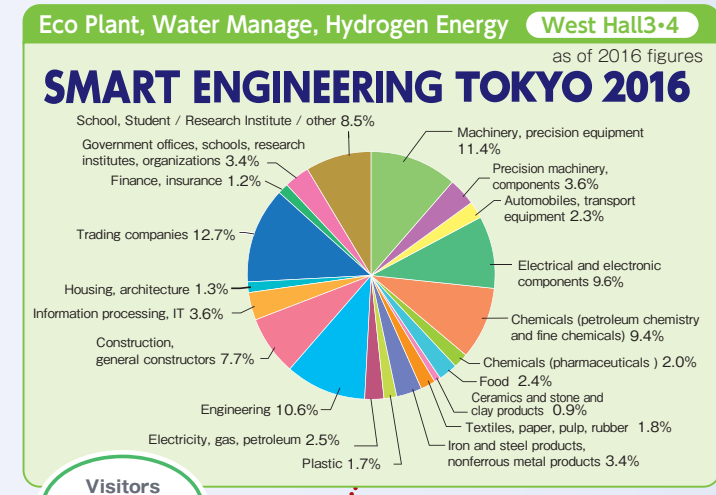

FREE ENTRANCE IN BETWEEN ALL 10 HALLS!

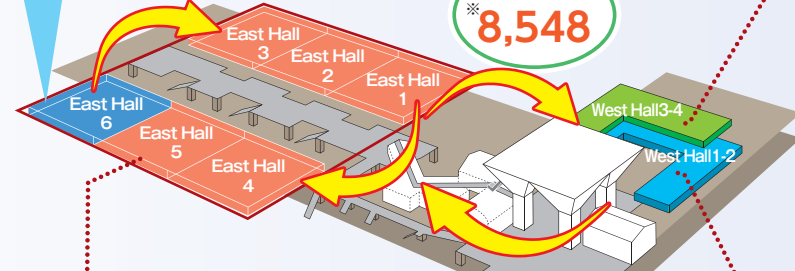

*ALL the visitor statistics are the number counted as 1 Registration per 1 person, regardless of how many times the visitors have repeatedly entered and exited the venue

